



ORTA DOĞU TEKNİK ÜNİVERSİTESİ
MIDDLE EAST TECHNICAL UNIVERSITY

ME 301

Theory of Machines I

Dr. Ergin TÖNÜK

Department of Mechanical Engineering
Graduate Program of Biomedical Engineering

<http://users.metu.edu.tr/tonuk>

tonuk@metu.edu.tr

3. Gears

Kinematically a *regular* gear pair is a form closed kinematic pair that is in permanent critical form. The relative motion can be represented as rolling of one *pitch circle* on the other therefore degree of freedom of the kinematic pair is actually one. However since it is in permanent critical form, to obtain true degree of freedom, for regular gear pairs (GP*) degree of freedom of the joint is *assumed* to be **2**.

Unlike linkage mechanisms, there is linear relationship between the angular velocities of the links connected by a gear pair. That is, the velocity influence coefficient is position independent and is a constant number. The same principle applies for belts (where slip is negligible for flat and v-belts, roller drives for timing belts and chain drives).

3. Gears



Flat Belt Drive

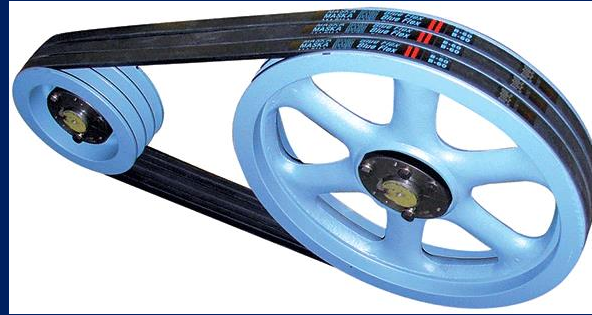

V- Belt Drive



Friction Drive

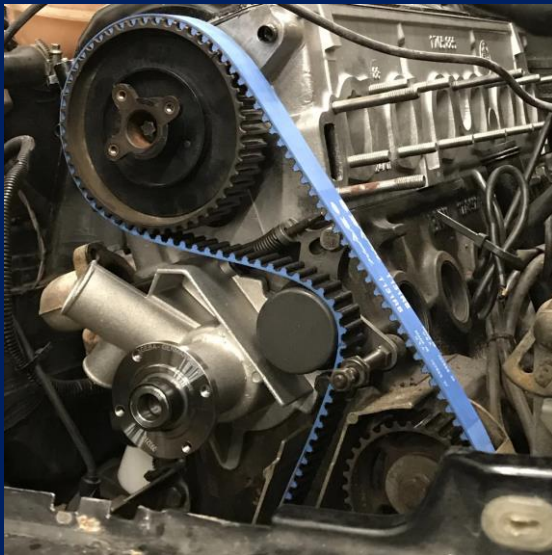

Timing Belt Drive



Chain Drive

3. Gears

Simple Gears:

External Mesh The axes of the gears are connected to the fixed link by revolute joints at a distance equal to sum of the radii of the two gears.

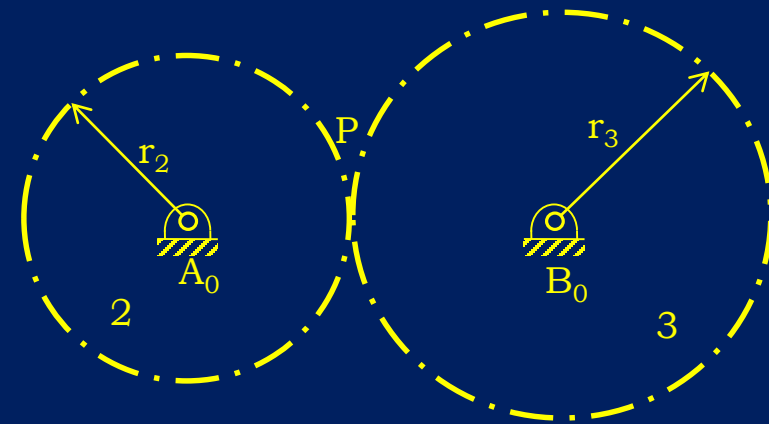
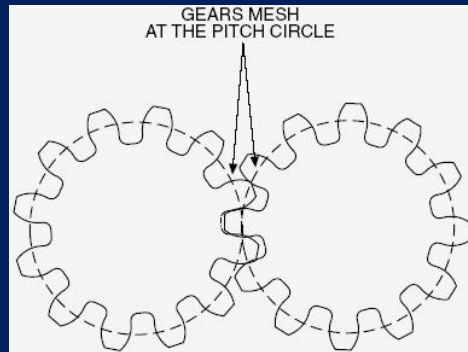
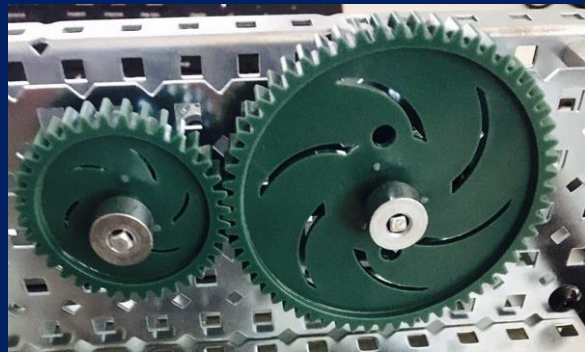

At point P there is rolling without slipping therefore:

$$V_{P_2} = \omega_{12}r_2 = V_{P_3} = -\omega_{13}r_3$$

$$R_{23} = \frac{\omega_{13}}{\omega_{12}} = -\frac{r_2}{r_3}$$

3. Gears

Simple Gears:

Internal Mesh, Ring Gear

At point P there is rolling without slipping:

$$V_{P_2} = \omega_{12}r_2 = V_{P_3} = \omega_{13}r_3$$

$$R_{23} = \frac{\omega_{13}}{\omega_{12}} = \frac{r_2}{r_3}$$

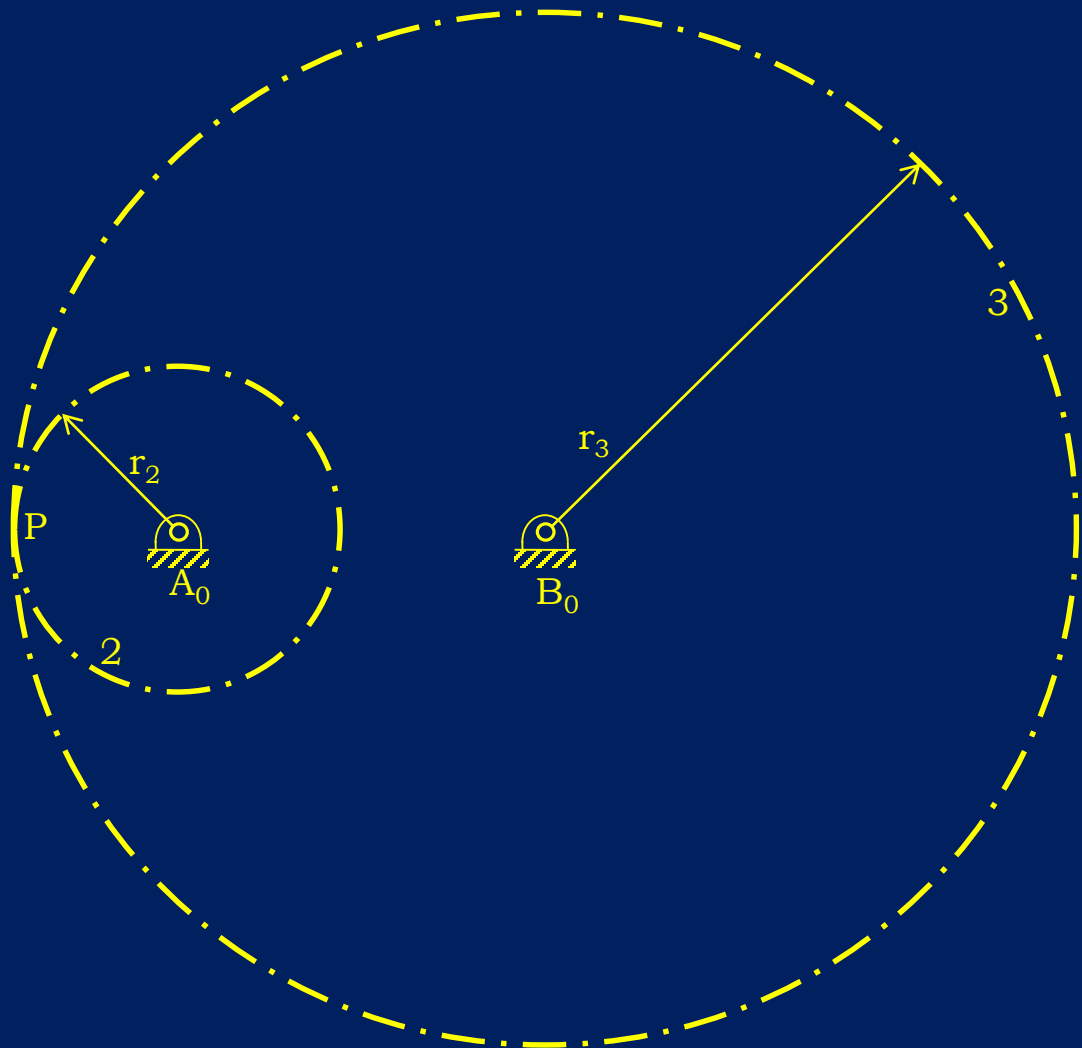

3. Gears

Simple Gear Trains:

$$R_{23} = \frac{\omega_{13}}{\omega_{12}} = -\frac{r_2}{r_3}$$

$$R_{34} = \frac{\omega_{14}}{\omega_{13}} = -\frac{r_3}{r_4}$$

$$R_{24} = \frac{\omega_{14}}{\omega_{12}} = \left(-\frac{r_2}{r_3}\right) \left(-\frac{r_3}{r_4}\right) = \frac{r_2}{r_4}$$

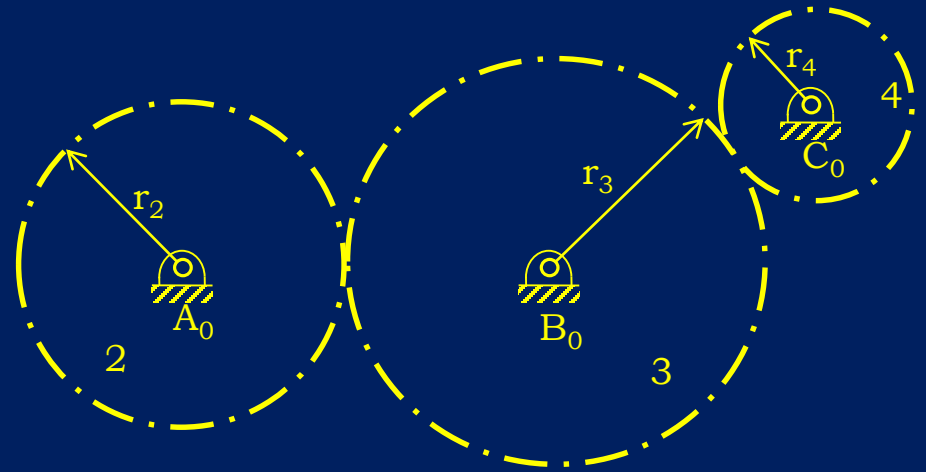

The *only* effect of gear 3 is to change the direction of rotation therefore mostly it is termed as *the idler gear*.

3. Gears

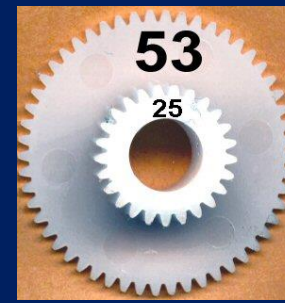

Compound Gear Trains:

If, at least one of the links contain more than one gear then the gear train is called a compound gear train.

$$R_{23} = \frac{\omega_{13}}{\omega_{12}} = -\frac{r_2}{r_3}$$

$$R_{34} = \frac{\omega_{14}}{\omega_{13}} = -\frac{r_3'}{r_4}$$

$$R_{24} = \frac{\omega_{14}}{\omega_{12}} = \left(-\frac{r_2}{r_3}\right) \left(-\frac{r_3'}{r_4}\right) = (-1)^k \frac{r_2 r_3'}{r_3 r_4} = (-1)^k \frac{\Pi \text{driving gear}}{\Pi \text{driven gear}}$$

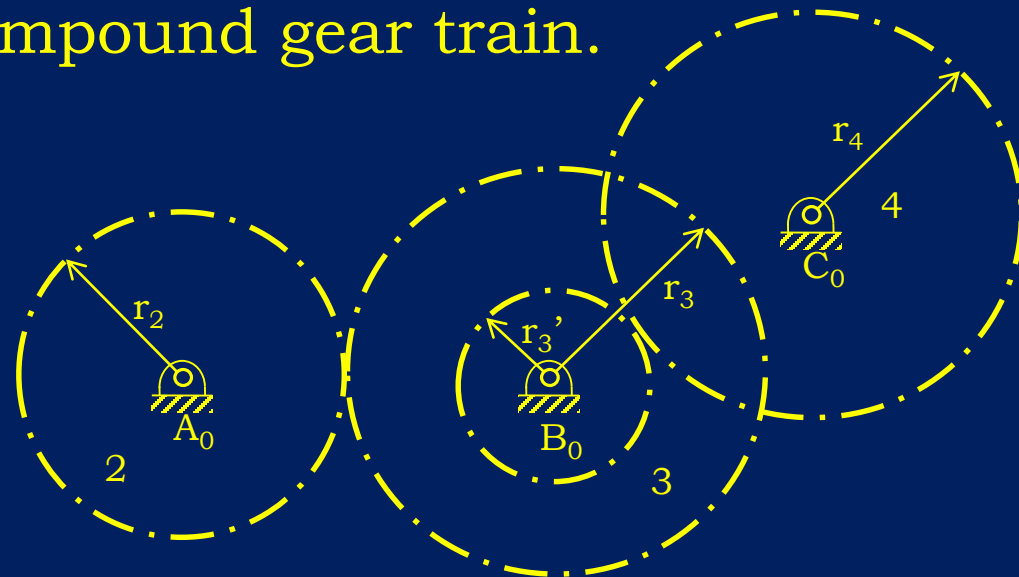

k is the number of external meshes

3. Gears

Law of Gearing

Two gears to be meshed, their tooth should be of the same *size*.

Size of a gear tooth is determined in two ways:

American Units: *Diametral Pitch*

$$P_D = \frac{T}{d} \text{ [tooth/inch]}$$

SI Units: *Module*

$$m = \frac{\pi d}{T} \text{ [mm]}$$

In both cases number of tooth is proportional to diameter (therefore radius) of the meshing gears.

3. Gears

Gear Terminology (Mainly in ME 308)

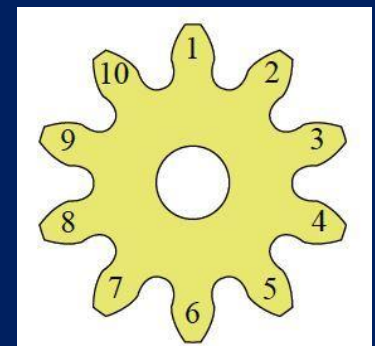
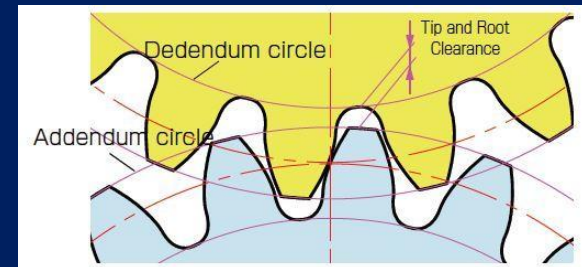
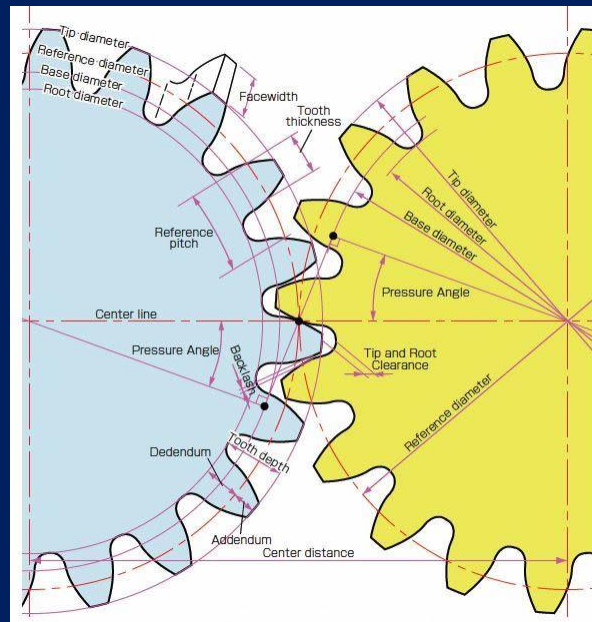
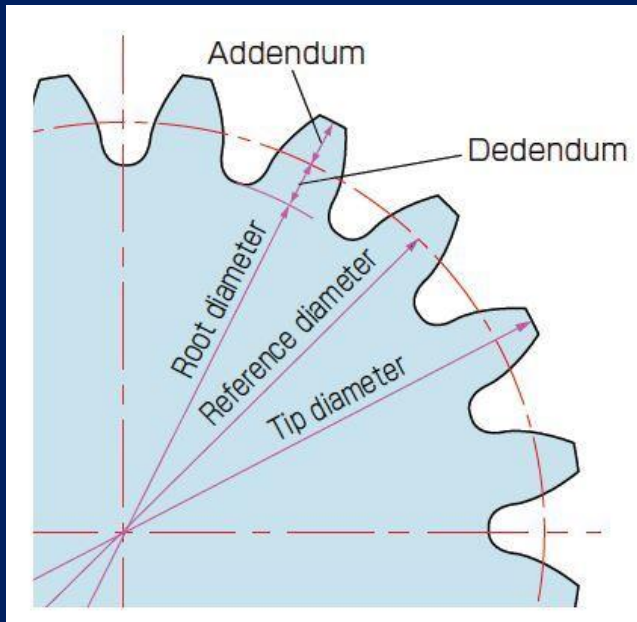
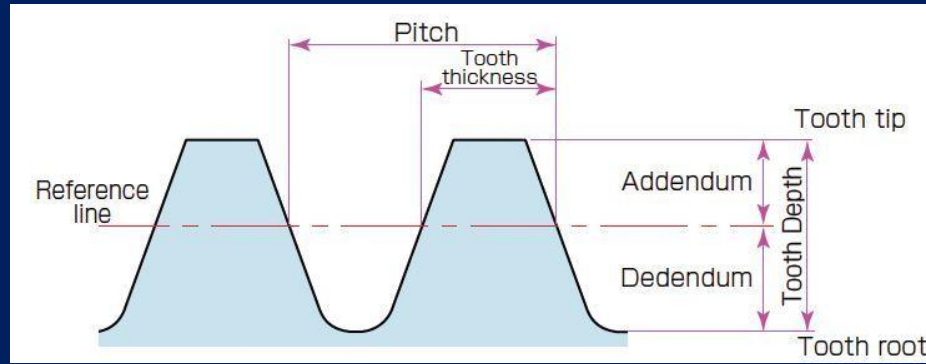
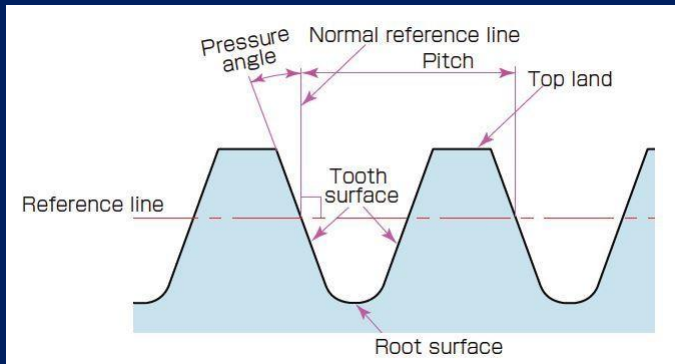

3. Gears

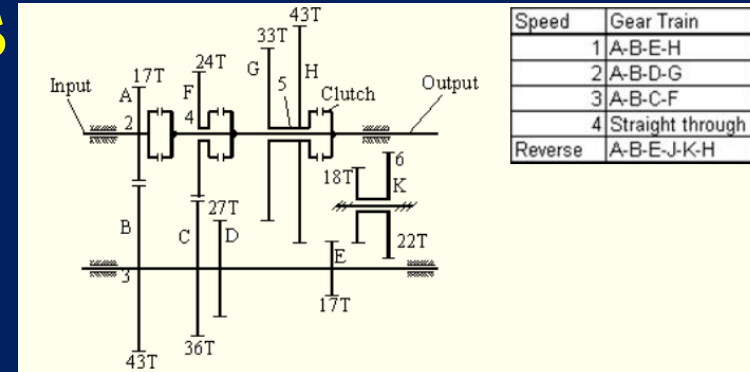

Example:

Four forward and one reverse speed automobile gearbox. Determine the speed ratios and rotation direction of the output shaft.

$$R_{io}^1 = (-1)^2 \frac{T_A T_E}{T_B T_H} = \frac{\omega_o}{\omega_i} = \frac{17 \times 17}{43 \times 43} = \frac{289}{1849} \cong 0.1563$$

$$R_{io}^2 = (-1)^2 \frac{T_A T_D}{T_B T_G} = \frac{\omega_o}{\omega_i} = \frac{17 \times 27}{43 \times 33} = \frac{153}{473} \cong 0.323$$

$$R_{io}^3 = (-1)^2 \frac{T_A T_C}{T_B T_F} = \frac{\omega_o}{\omega_i} = \frac{17 \times 36}{43 \times 24} = \frac{51}{86} \cong 0.593$$

$$R_{io}^4 = 1$$

$$R_{io}^R = (-1)^3 \frac{T_A T_E T_K}{T_B T_J T_H} = \frac{\omega_o}{\omega_i} = -\frac{17 \times 17 \times 22}{43 \times 18 \times 43} = -\frac{3179}{16641} \cong -0.1910$$

3. Gears

Planetary Gear Trains:

At least one gear is *not* directly connected to the fixed link by a revolute joint, the gear train is planetary gear train.

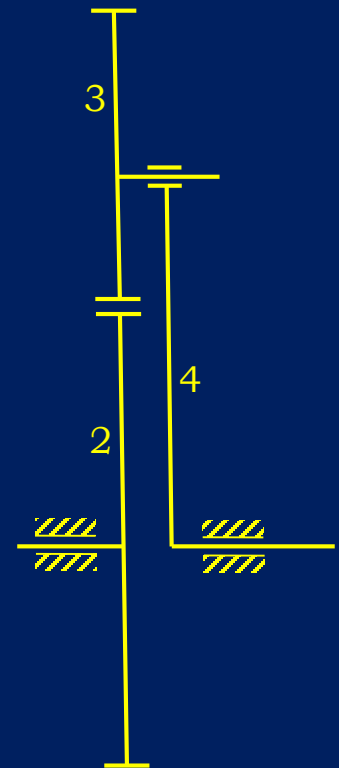
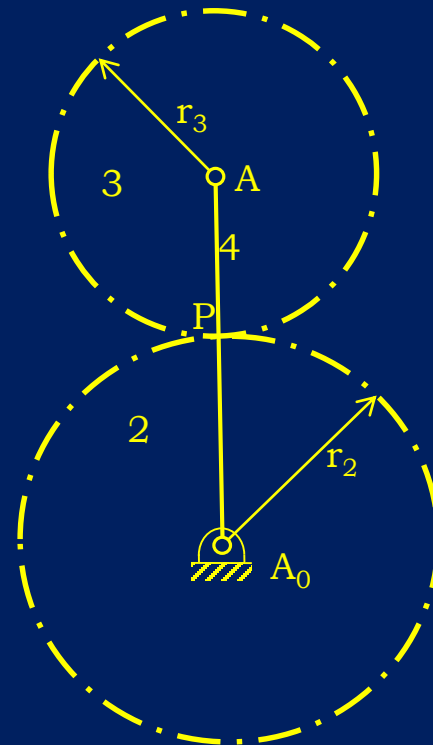
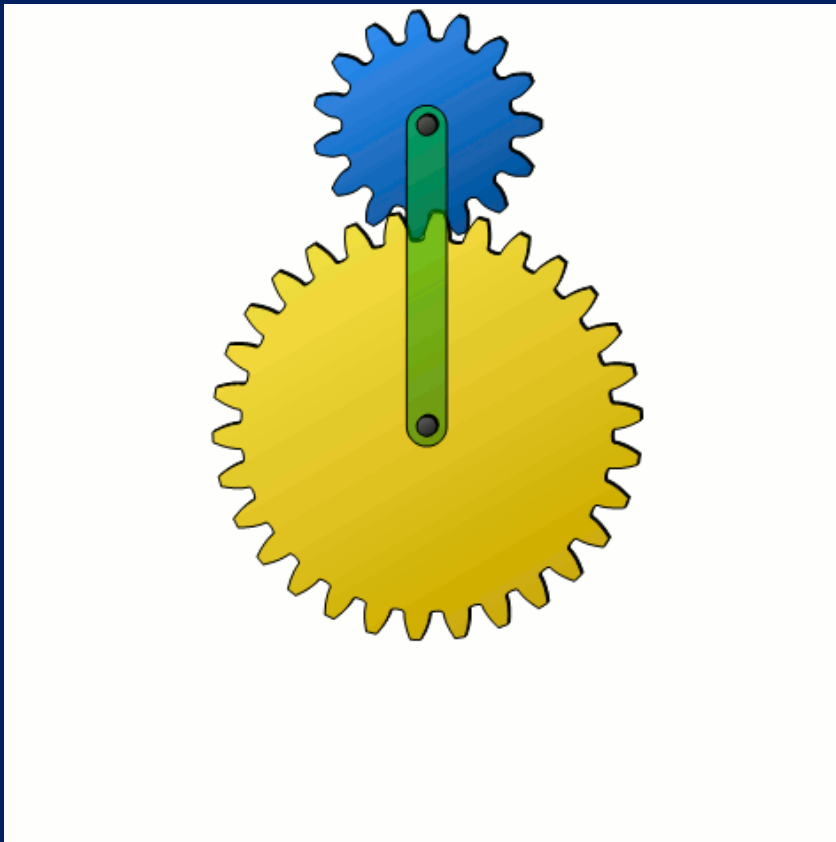

3. Gears

Planetary Gear Trains:

$$F = \lambda(\ell - j - 1) + \sum_{i=1}^j f_i$$

$$\lambda = 3$$

$$\ell = 4$$

$$j = 4 (3R + GP^*)$$

$$\sum_{i=1}^4 f_i = 5$$

$$F = 3(4 - 4 - 1) + 5 = 2$$

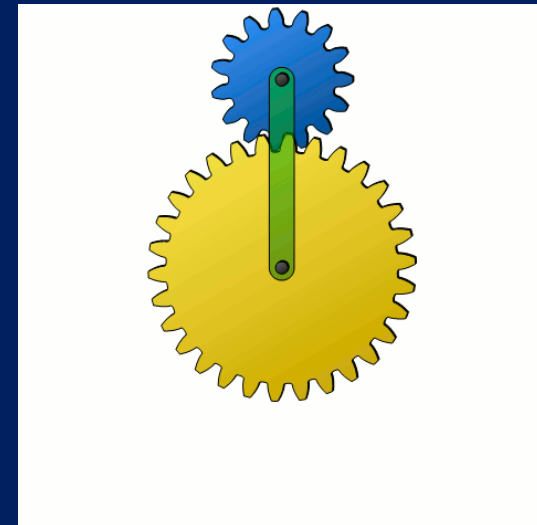
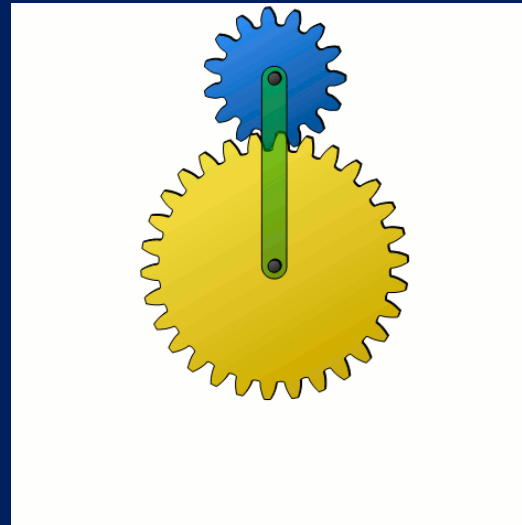
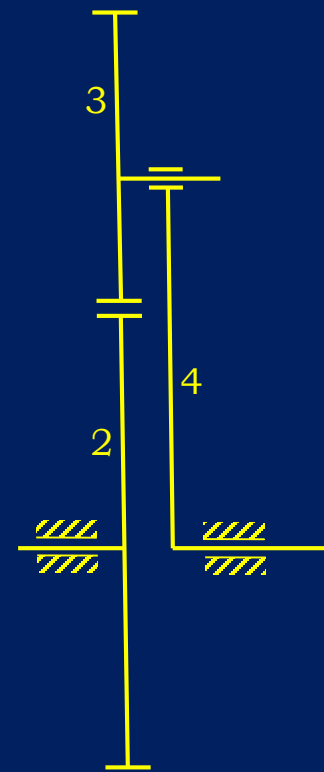

3. Gears

Planetary Gear Trains:

Assume all angular velocities counter clockwise positive:

$$V_{P_2} = V_{P_3}$$

$$V_{P_2} = \omega_{12}r_2 (\leftarrow)$$

$$V_{P_3} = V_A + V_{P_3/A} = \omega_{14}(r_2 + r_3) - \omega_{13}r_3 (\leftarrow)$$

$$\omega_{12}r_2 = \omega_{14}(r_2 + r_3) - \omega_{13}r_3$$

$$R_{23} = -\frac{r_2}{r_3} = \frac{\omega_{13} - \omega_{14}}{\omega_{12} - \omega_{14}}$$

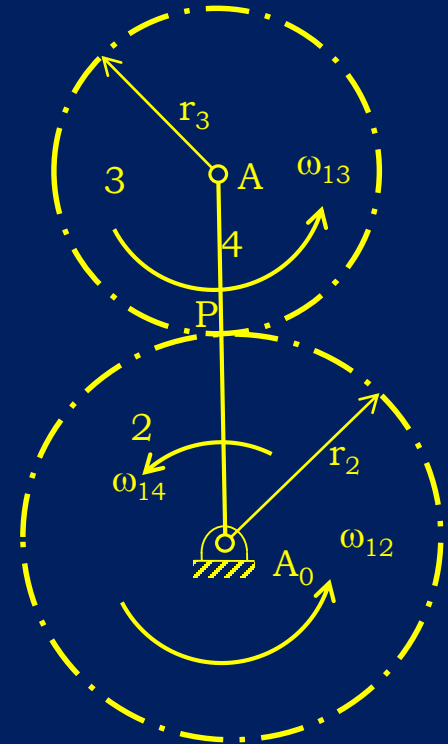

3. Gears

Planetary Gear Trains:

$$V_{P_2} = V_{P_3}$$

$$V_{P_2} = \omega_{12} r_2 (\leftarrow)$$

$$V_{P_3} = V_A + V_{P_3/A} = \omega_{14}(r_2 - r_3) + \omega_{13} r_3 (\leftarrow)$$

$$\omega_{12} r_2 = \omega_{14}(r_2 - r_3) + \omega_{13} r_3$$

$$R_{23} = \frac{r_2}{r_3} = \frac{\omega_{13} - \omega_{14}}{\omega_{12} - \omega_{14}}$$

$$R_{ij} = \mp \frac{r_i}{r_j} = \mp \frac{T_i}{T_j} = \frac{\omega_{1j} - \omega_{1\text{arm}}}{\omega_{1i} - \omega_{1\text{arm}}}$$

- for sun, + for ring gear

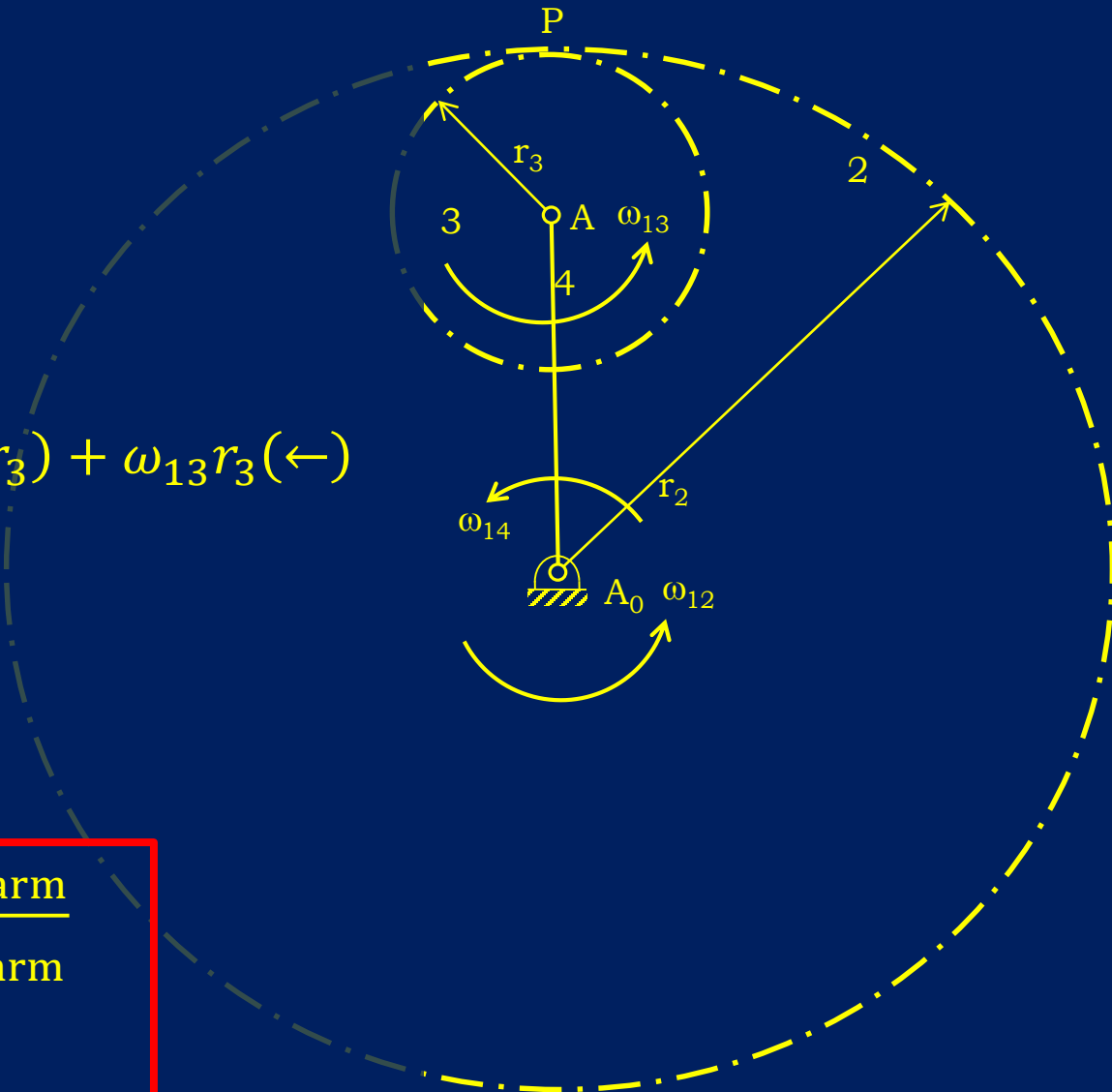

3. Gears

Example:

Given $\omega_{12} = 150 \text{ rpm (CW)}$, $\omega_{14} = 100 \text{ rpm (CCW)}$, determine ω_{13} for $T_2 = 60$ and $T_3 = 22$.

$$R_{23} = -\frac{T_2}{T_3} = -\frac{60}{22} = \frac{\omega_{13} - \omega_{14}}{\omega_{12} - \omega_{14}} = \frac{\omega_{13} - 100}{-150 - 100}$$

$$\omega_{13} = 782 \text{ rpm (CCW)}$$

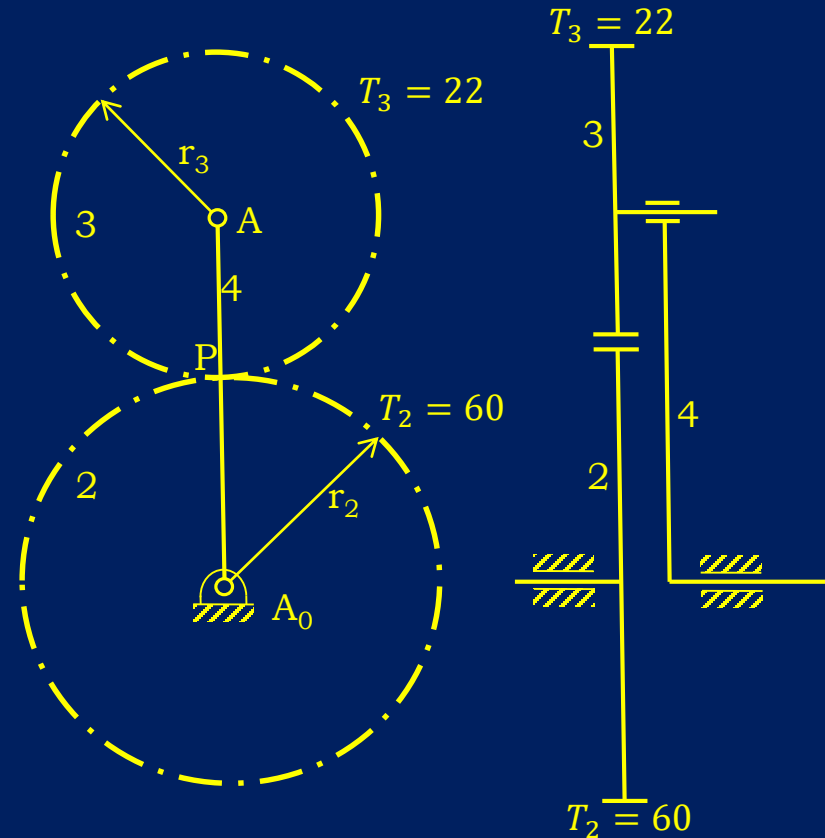

3. Gears

Example:

Determine the output speed and direction of rotation for $\omega_{12} = 3000 \text{ rpm}$

Mesh 1, planetary, arm 2, external

$$R_{34} = -\frac{T_3}{T_4} = -\frac{40}{38} = \frac{\omega_{14} - \omega_{12}}{\omega_{13} - \omega_{12}}$$

Mesh 2, planetary, arm 2, external

$$R_{3'5} = -\frac{T_{3'}}{T_5} = -\frac{42}{36} = \frac{\omega_{15} - \omega_{12}}{\omega_{13} - \omega_{12}}$$

Mesh 3, simple, internal

$$R_{56} = \frac{T_5}{T_6} = \frac{120}{54} = \frac{\omega_{16}}{\omega_{15}}$$

Mesh 4, simple, external

$$R_{4'6} = -\frac{T_{4'}}{T_6} = -\frac{12}{54} = \frac{\omega_{16}}{\omega_{14}}$$

Four equations–four unknowns, $\omega_{16} = -\frac{26}{1305} \omega_{12}$

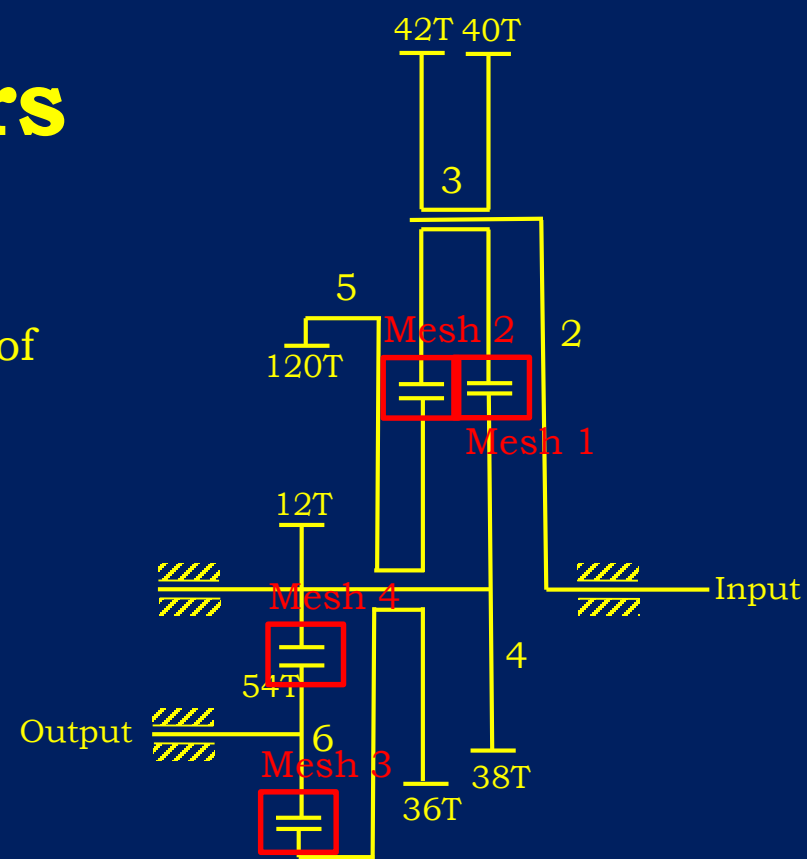

3. Gears

Example:

Determine $\frac{\omega_{14}}{\omega_{12}}$

Mesh 1, planetary, arm 4, external

$$R_{23} = -\frac{T_2}{T_3} = -\frac{24}{60} = \frac{\omega_{13} - \omega_{14}}{\omega_{12} - \omega_{14}}$$

Mesh 2, planetary, arm 4, internal

$$R_{31} = \frac{T_{3'}}{T_1} = \frac{18}{102} = \frac{\omega_{11} - \omega_{14}}{\omega_{13} - \omega_{14}}$$

$$R_{23} \times R_{31} = \frac{\omega_{13} - \omega_{14}}{\omega_{12} - \omega_{14}} \times \frac{-\omega_{14}}{\omega_{13} - \omega_{14}} = -\frac{24}{60} \times \frac{18}{102} = -\frac{6}{85}$$

$$\frac{\omega_{14}}{\omega_{12}} = \frac{6}{91}$$

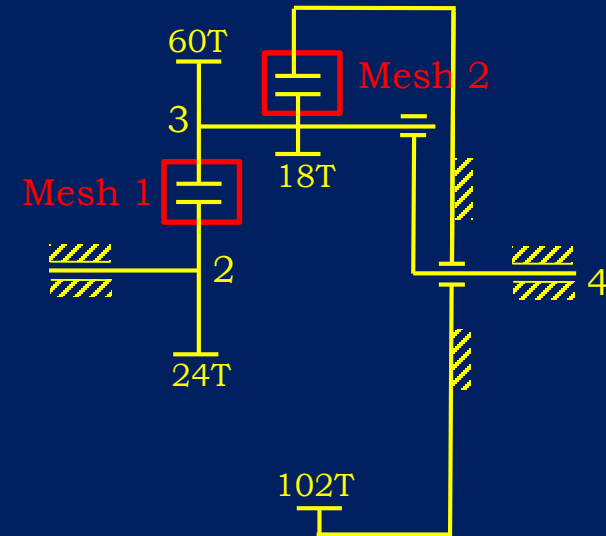

3. Gears

Example:

Determine $\frac{\omega_{14}}{\omega_{12}}$

Mesh 1, planetary, arm 2, internal

$$R_{13} = \frac{T_1}{T_3} = \frac{100}{20} = \frac{\omega_{13} - \omega_{12}}{\omega_{11} - \omega_{12}}$$

Mesh 2, planetary, arm 2, internal

$$R_{34} = \frac{T_{3'}}{T_4} = \frac{25}{105} = \frac{\omega_{14} - \omega_{12}}{\omega_{13} - \omega_{12}}$$

$$R_{13} \times R_{34} = \frac{\omega_{13} - \omega_{12}}{-\omega_{12}} \times \frac{\omega_{14} - \omega_{12}}{\omega_{13} - \omega_{12}} = \frac{100}{20} \times \frac{25}{105} = \frac{25}{21}$$

$$\frac{\omega_{14}}{\omega_{12}} = \frac{4}{25}$$

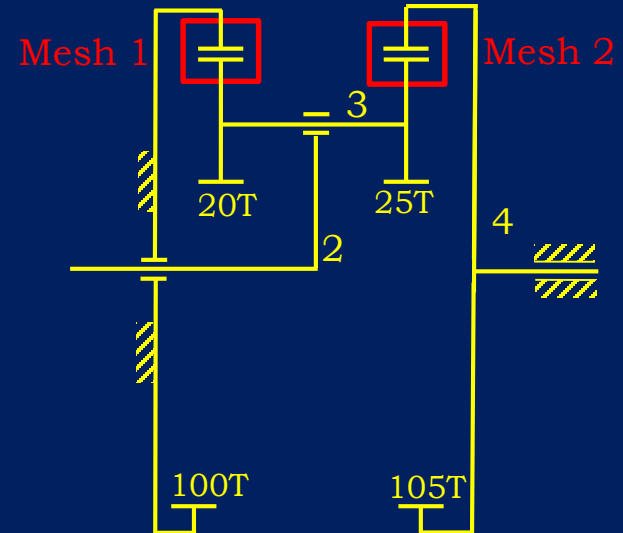

3. Gears

Bevel Gears



Floodgate power screw operated by bevel gear

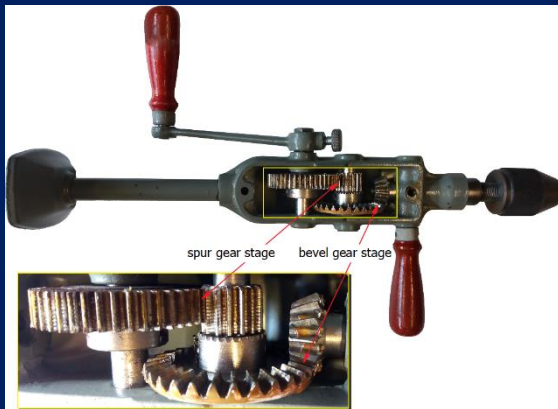
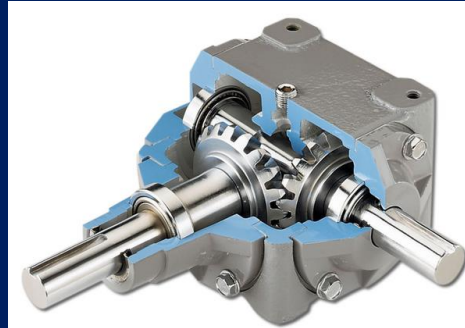

Hand powered drill



3. Gears

Bevel Gears

In bevel gears since rotation axes of two meshing gears are **not** parallel, the sign convention in simple and planetary gear trains **do not** work.

For simple bevel gears inspection works very well.

⊙ Designates velocity vector tip (out of page)

⊗ Designates velocity vector tail (into page)

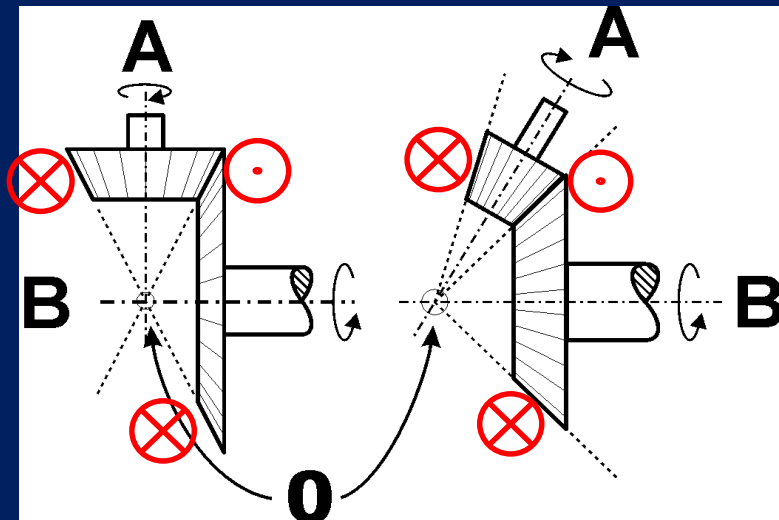

3. Gears

Example:

Determine $\frac{\omega_{14}}{\omega_{12}}$

Mesh 1, bevel, simple

$$R_{23} = \frac{T_2}{T_3} = \frac{20}{80} = \frac{\omega_{13}}{\omega_{12}} \text{ (Direction on figure!)}$$

Mesh 2, bevel, simple

$$R_{34} = \frac{T_{3'}}{T_4} = \frac{18}{60} = \frac{\omega_{14}}{\omega_{13}}$$

$$R_{23} \times R_{34} = \frac{\omega_{13}}{\omega_{12}} \times \frac{\omega_{14}}{\omega_{13}} = \frac{\omega_{14}}{\omega_{12}} = \frac{20}{80} \times \frac{18}{60} = \frac{3}{40}$$

Since shafts 2 and 4 are parallel and rotate in the same direction (obtained by **inspection**)

$$\frac{\omega_{14}}{\omega_{12}} = +\frac{3}{40}$$

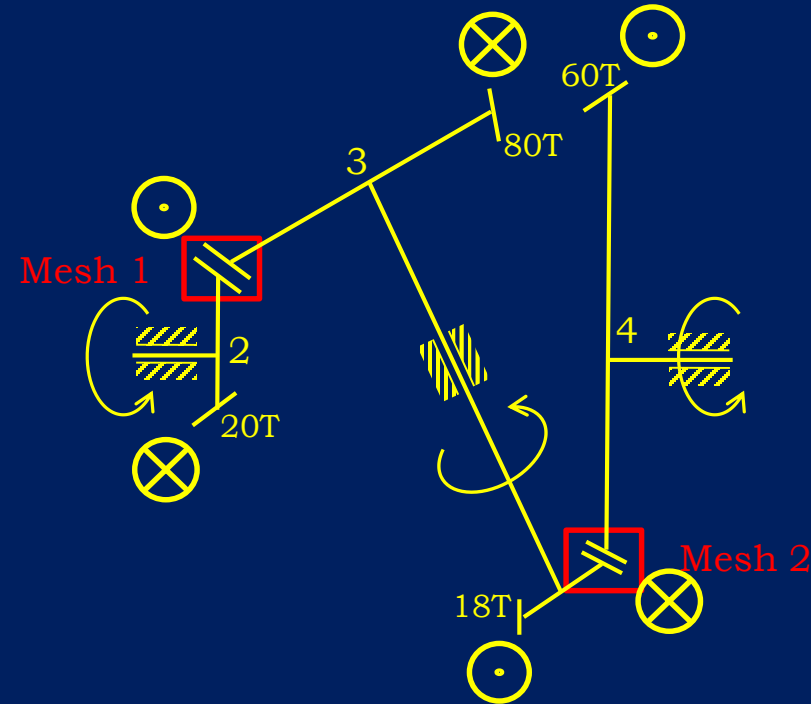

3. Gears

Bevel Gears

For planetary bevel gears,

1. Fix the arm, let the fixed (if any) gears move.
2. Write the gear ratio of the simple gear train *with proper signs*, equate it to the speed ratio of the planetary gear train.
3. If result is + then output is in the same direction obtained in (2) if – opposite direction to (2).

3. Gears

Example: (3.5 of textbook)

Determine $\frac{\omega_{14}}{\omega_{12}}$

1. Fix the arm (2), let the fixed (if any) gears (1→1') move
2. Write the gear ratio of the simple gear train with proper signs, equate it to the speed ratio of the planetary gear train

$$R_{1'4} = \frac{T_1 \times T_{3'}}{T_3 \times T_4} = \frac{40 \times 42}{20 \times 18} = \frac{14}{3} = \frac{\omega_{14} - \omega_{12}}{\omega_{11} - \omega_{12}}$$

3. If result is + then output is in the same direction obtained in (2) if - opposite direction to (2).

$$\frac{\omega_{14}}{\omega_{12}} = -\frac{11}{3}$$

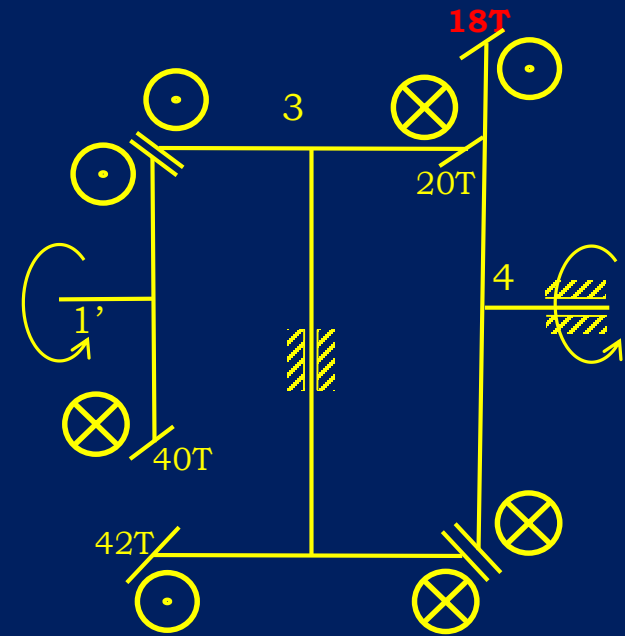
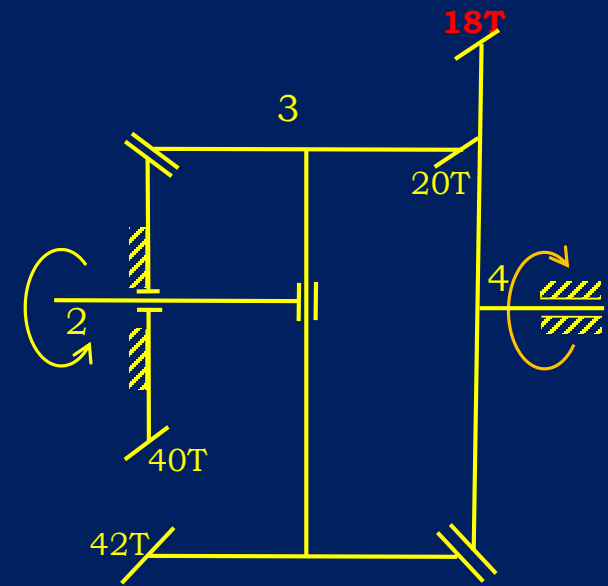

3. Gears

Example: (Car differential)

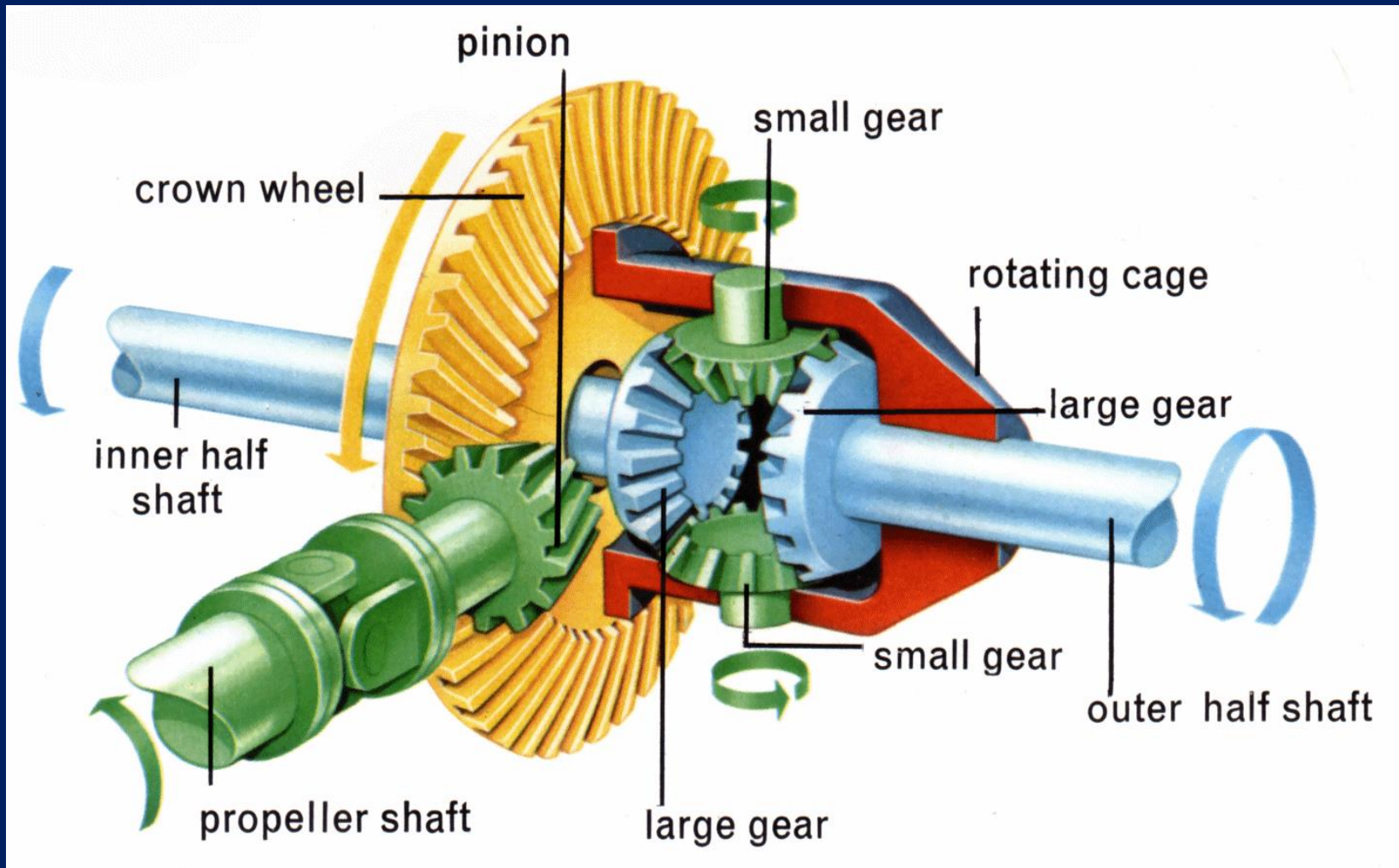

3. Gears

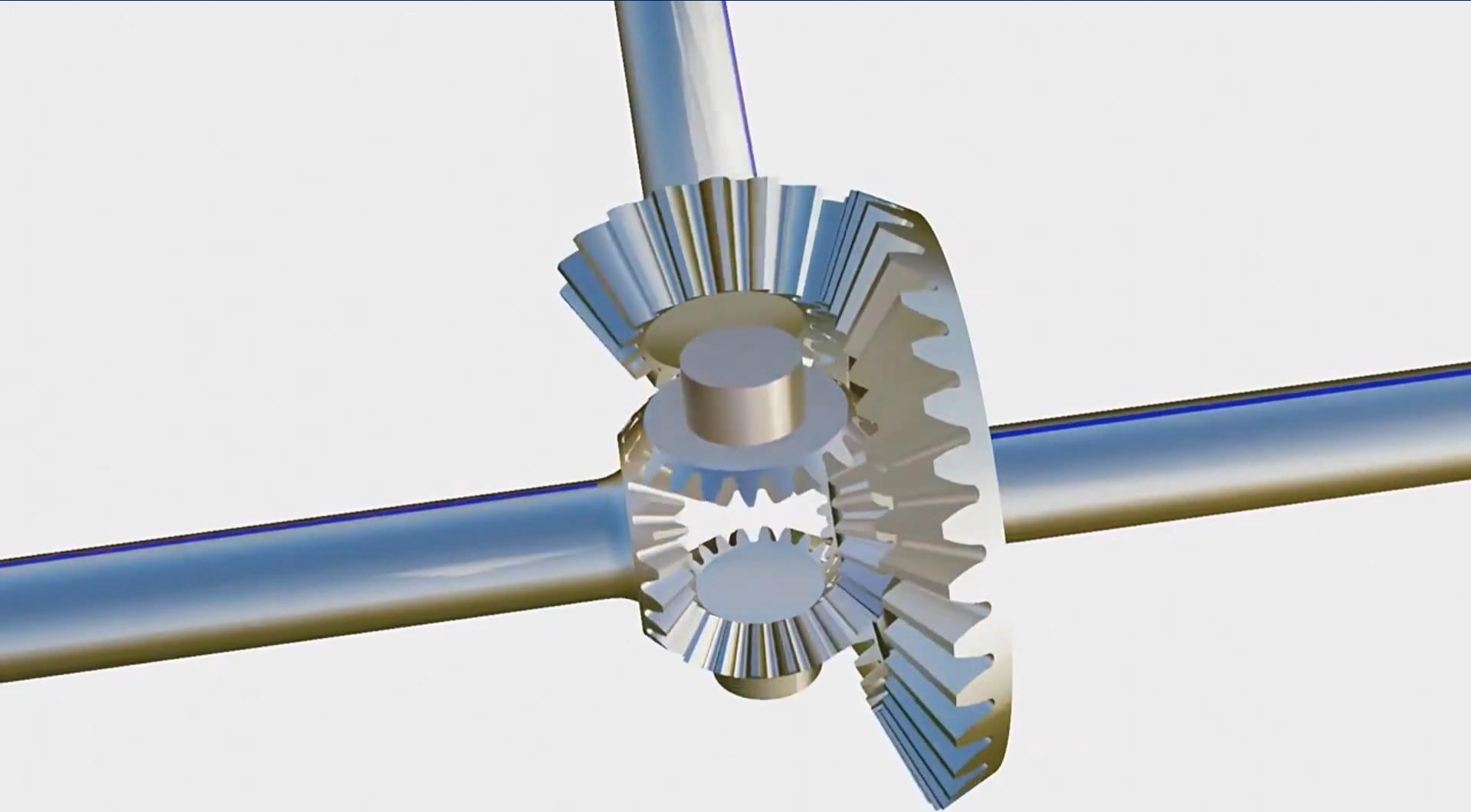

<https://www.youtube.com/watch?v=LrkWjpdK66E>

3. Gears

Example: (Car differential)

$$R_{23} = \frac{T_2}{T_3} = \frac{16}{48} = \frac{\omega_{13}}{\omega_{12}} \text{ (Direction on figure by inspection!)}$$

1. Fix the arm (3), let the fixed (none) gears move
2. Write the gear ratio of the simple gear train with proper signs, equate it to the speed ratio of the planetary gear train

$$R_{56} = \frac{T_5 \times T_4}{T_4 \times T_6} = \frac{20 \times 14}{14 \times 20} = -1 = \frac{\omega_{16} - \omega_{13}}{\omega_{15} - \omega_{13}}$$

$$\omega_{15} + \omega_{16} = \frac{2}{3}\omega_{12}$$

On straight road,

$$\omega_{15} = \omega_{16} = \frac{\omega_{12}}{3}$$

On a curve

$$\omega_{15} \neq \omega_{16}$$

This is a $F = 2$ mechanism but there is only one input. The road conditions determine the motion, underactuation.

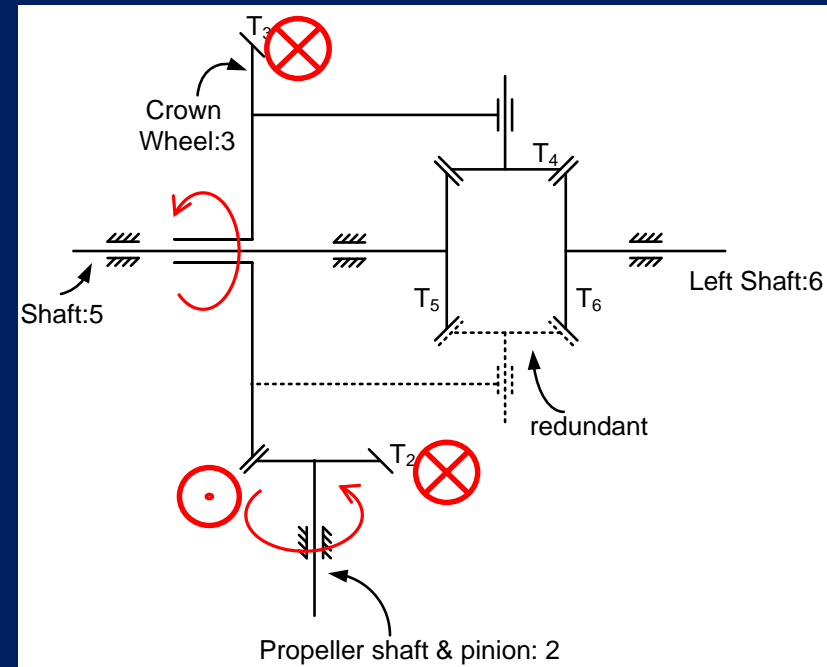

Typical Tooth Number

$$T_2 = 16$$

$$T_3 = 48$$

$$T_4 = 14$$

$$T_5 = T_6 = 20$$

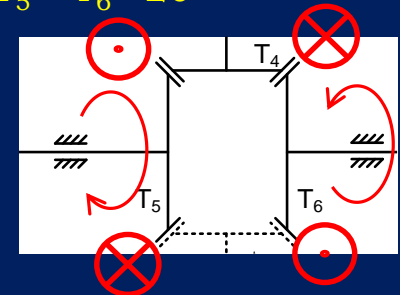

Thank You!

3. Gears

Example: (3.6 of textbook)

Determine $\frac{\omega_{14}}{\omega_{12}}$

1. Fix the arm (5), let the fixed (if any) gears (1→1') move
2. Write the gear ratio of the simple gear train with proper signs, equate it to the speed ratio of the planetary gear train

$$R_{24} = \frac{T_2 \times T_{3'}}{T_3 \times T_4} = \frac{20 \times 24}{56 \times 35} = \frac{12}{49} = \frac{\omega_{14} - \omega_{15}}{\omega_{12} - \omega_{15}}$$

$$R_{1'2} = \frac{T_1 \times T_3}{T_3 \times T_2} = \frac{76}{20} = \frac{19}{5} = \frac{\omega_{12} - \omega_{15}}{\omega_{11} - \omega_{15}} \rightarrow \omega_{15} = \frac{5}{14} \omega_{12}$$

3. If result is + then output is in the same direction obtained in (2) if - opposite direction to (2). **SONUÇ HATALI!**

$$\frac{\omega_{14}}{\omega_{12}} = -\frac{11}{3}$$

